

CSCI 420 Computer Graphics  
Lecture 8

# Hierarchical Models

Projections and Shadows  
Hierarchical Models  
[Angel Ch. 8]

Jernej Barbic  
University of Southern California

# Roadmap

- Last lecture: Viewing and projection
- Today:
  - Shadows via projections
  - Hierarchical models
- Next: Polygonal Meshes, Curves and Surfaces
- Goal: background for Assignment 2 (next week)

# Importance of shadows

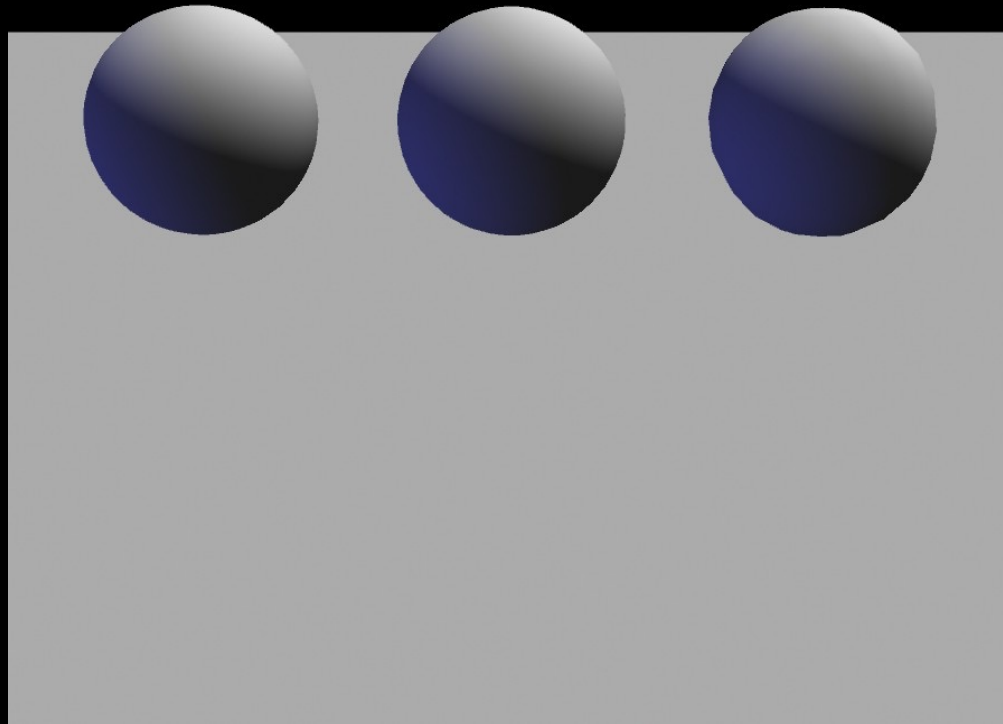

Source: UNC

# Importance of shadows

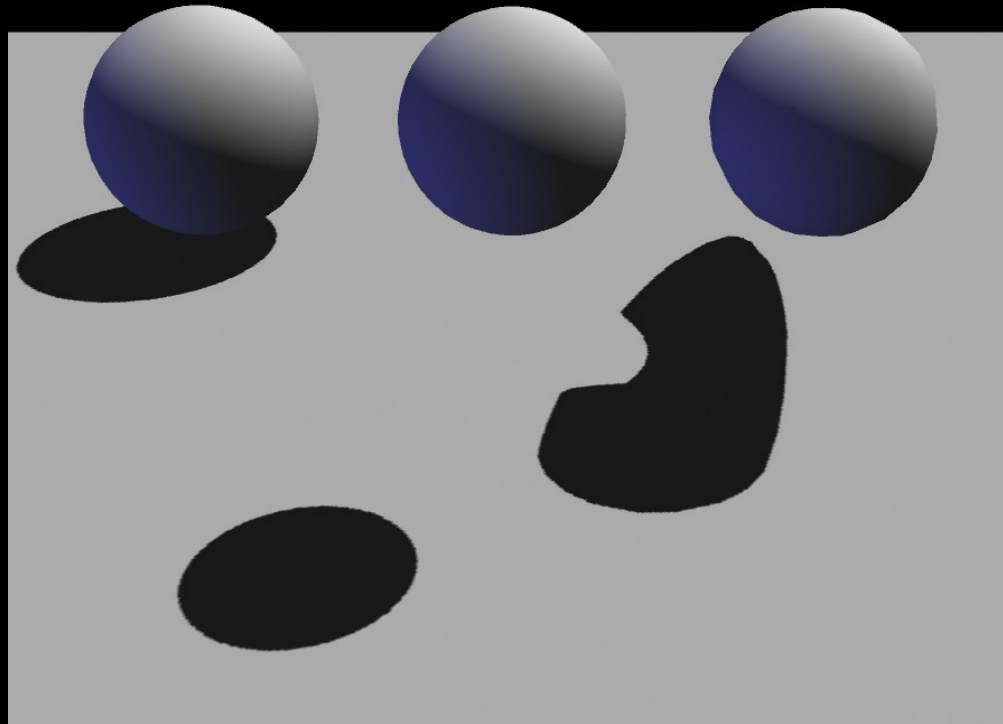

# Importance of shadows

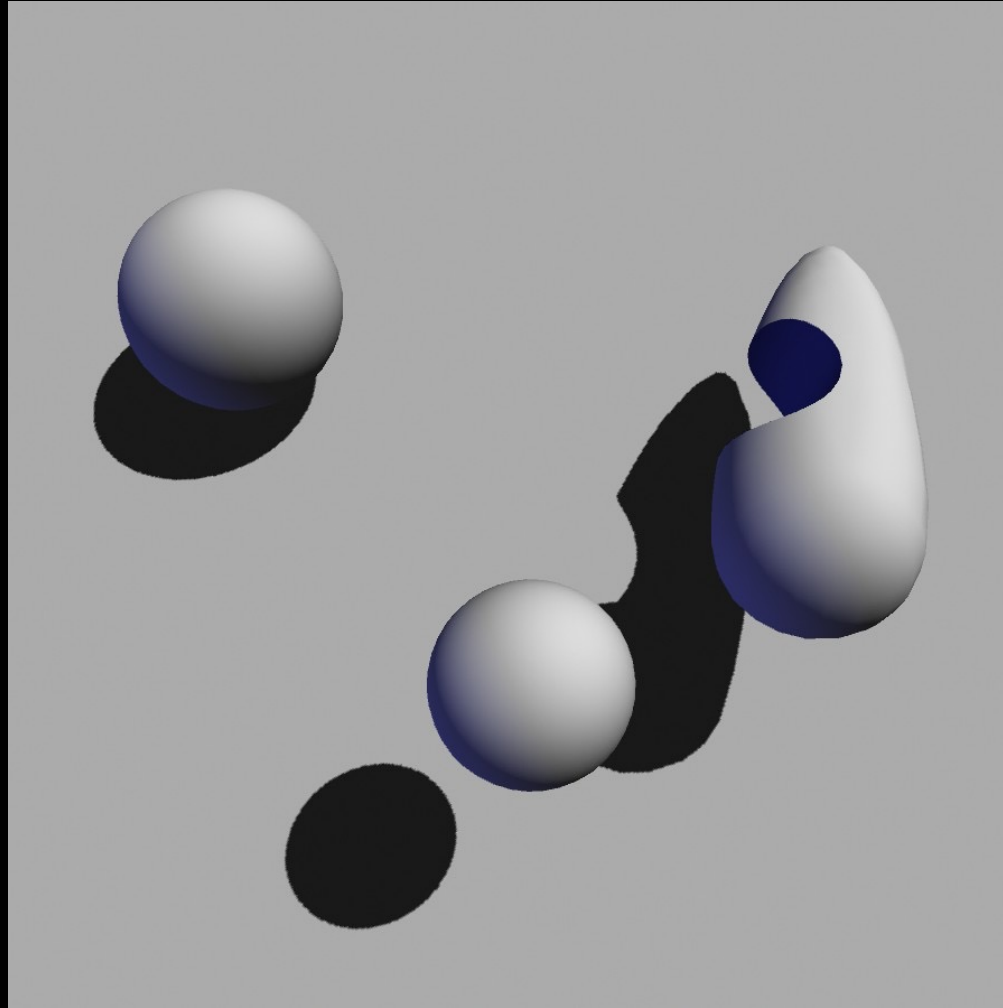

# Importance of shadows

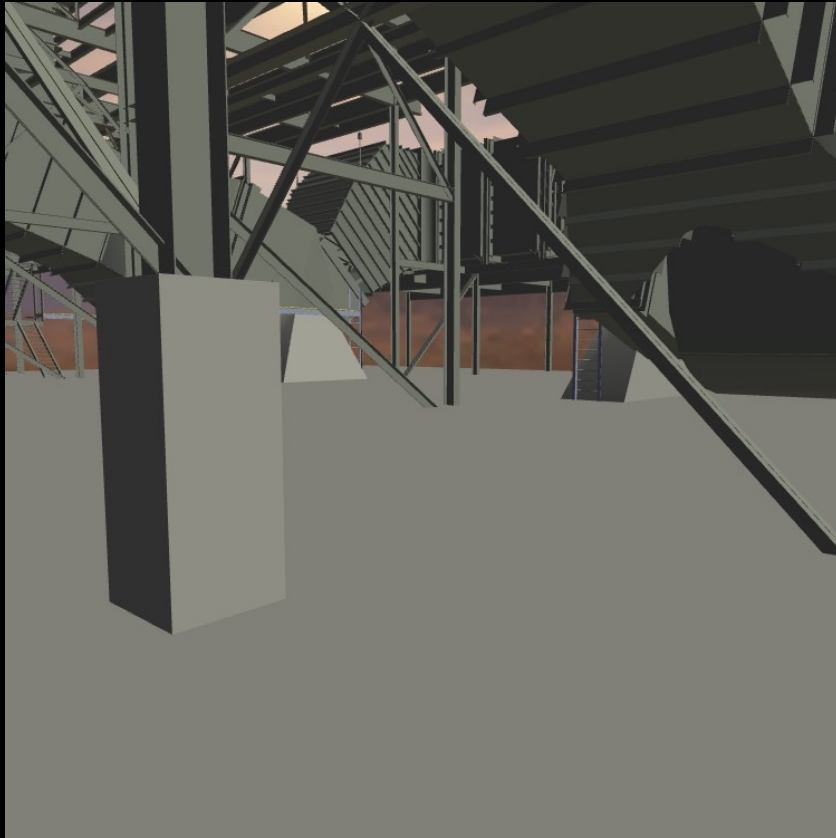

Without shadows

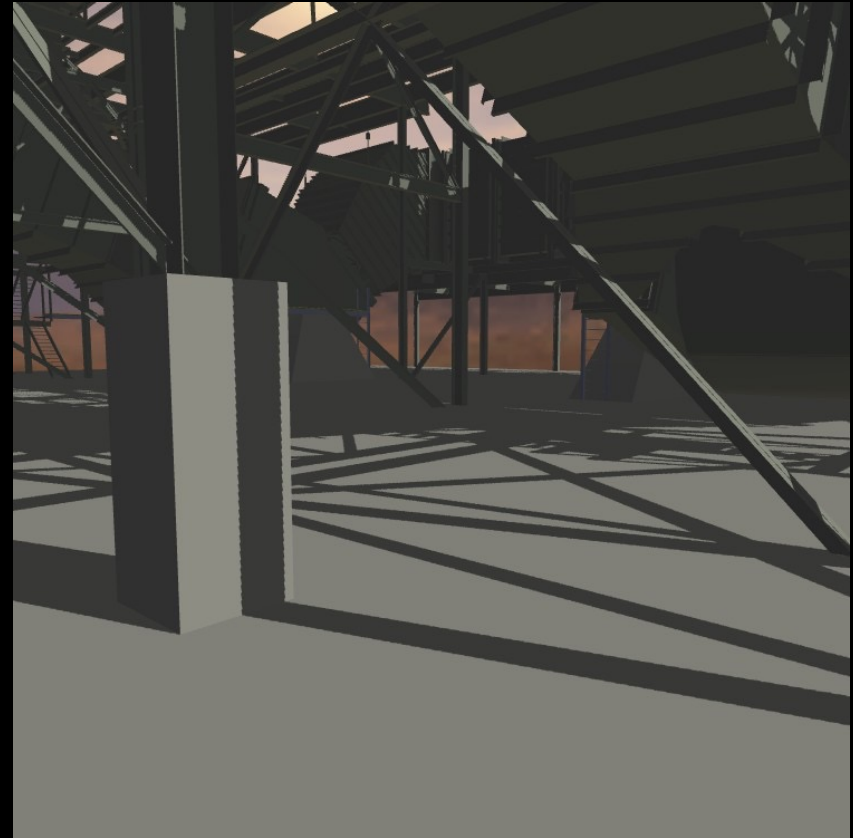

With shadows

Source: UNC

# Doom III



Reported to spend 50% of time rendering shadows!

Source: Wikipedia

# Light sources

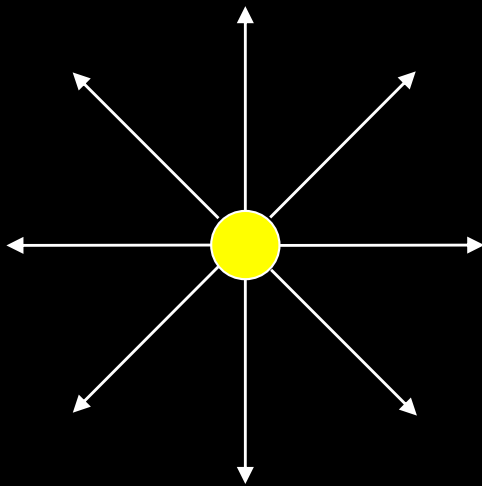

point  
light source

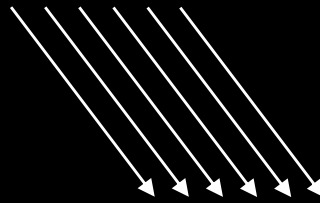

directional  
light source

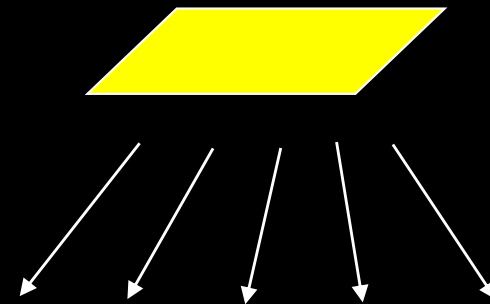

area  
light source



# Hard and soft shadows



point light

area light

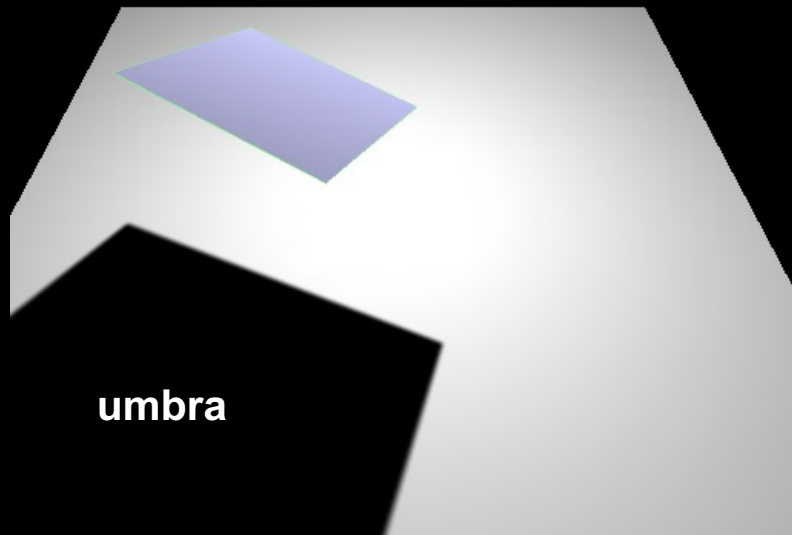

umbra

Hard shadow

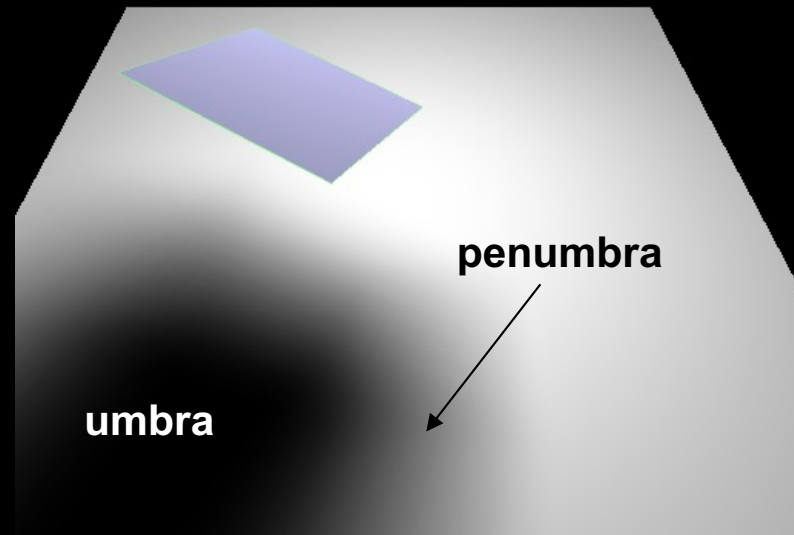

umbra

penumbra

Soft shadow

Source: UNC

# Shadow Algorithms

- With visibility tests
  - Accurate yet expensive
  - Example: ray casting or ray tracing
  - Example: 2-pass z-buffer  
[Foley, Ch. 16.4.4] [RTR 6.12]
- Without visibility tests (“fake” shadows)
  - Approximate and inexpensive
  - Using a model-view matrix “trick”

# Projection-based Shadows

- Assume light source at  $[x_l \ y_l \ z_l]^T$
- Assume shadow on plane  $y = 0$
- Construct a modelview matrix to flatten the geometry onto the shadow plane

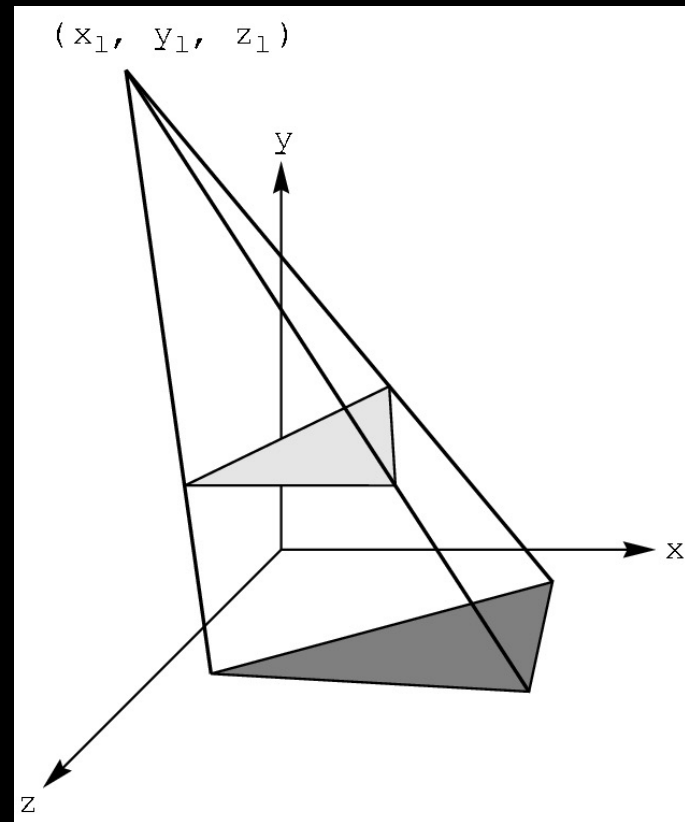

# Shadow Projection Strategy

- Move light source to origin
- Apply appropriate projection matrix
- Move light source back
- Instance of general strategy: compose complex transformation from simpler ones!

$$T = \begin{bmatrix} 1 & 0 & 0 & -x_l \\ 0 & 1 & 0 & -y_l \\ 0 & 0 & 1 & -z_l \\ 0 & 0 & 0 & 1 \end{bmatrix}$$

# Derive Equation

- Now, light source at origin

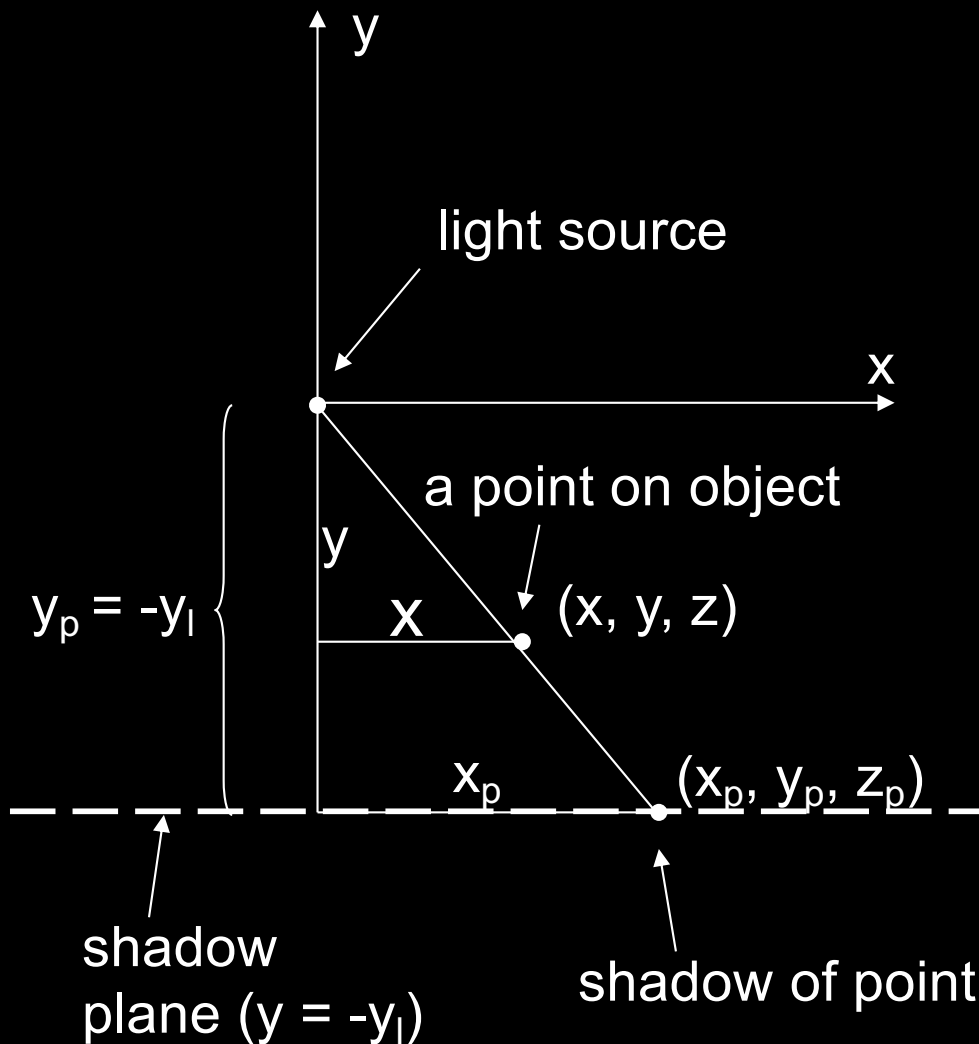

$$\frac{x_p}{y_p} = \frac{x}{y} \quad (\text{see picture})$$

$$y_p = -y_l \quad (\text{move light})$$

$$x_p = \frac{x}{y} y_p = -\frac{x}{y} y_l$$

$$z_p = \frac{z}{y} y_p = -\frac{z}{y} y_l$$

# Light Source at Origin

- After translation, solve

$$M \begin{bmatrix} x \\ y \\ z \\ 1 \end{bmatrix} = w \begin{bmatrix} -\frac{xy_l}{y} \\ -y_l \\ -\frac{zy_l}{y} \\ 1 \end{bmatrix}$$

- $w$  can be chosen freely
- Use  $w = -y / y_l$

$$M \begin{bmatrix} x \\ y \\ z \\ 1 \end{bmatrix} = \begin{bmatrix} x \\ y \\ z \\ -\frac{y}{y_l} \end{bmatrix}$$

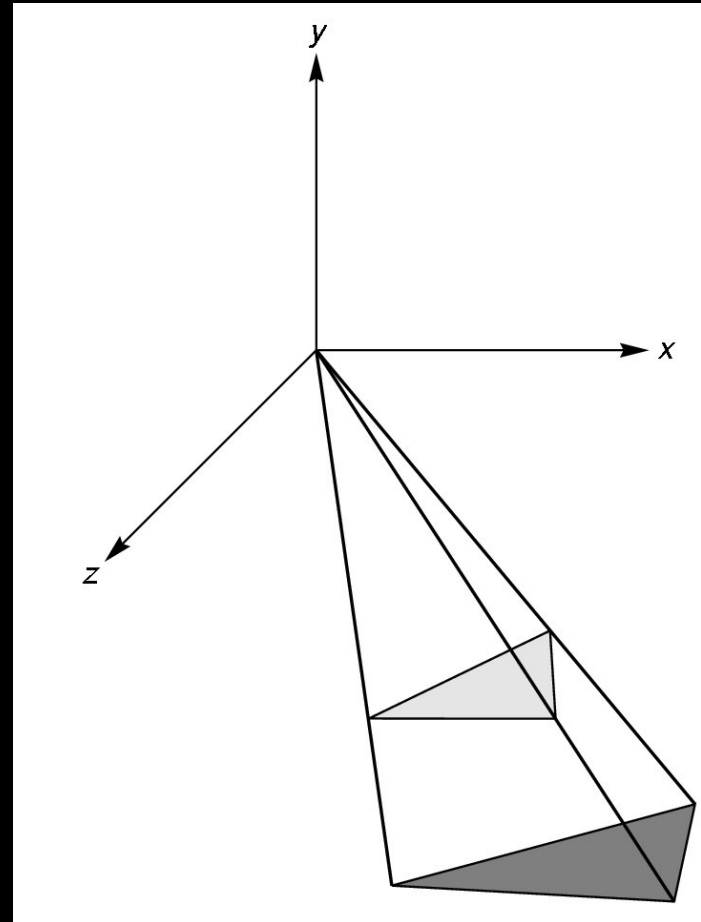

# Shadow Projection Matrix

- Solution of previous equation

$$M = \begin{bmatrix} 1 & 0 & 0 & 0 \\ 0 & 1 & 0 & 0 \\ 0 & 0 & 1 & 0 \\ 0 & -\frac{1}{y_l} & 0 & 0 \end{bmatrix}$$

- Total shadow projection matrix

$$S = T^{-1}MT = \dots$$

# Implementation

- Recall column-major form

```
GLfloat m[16] =  
{1.0, 0.0, 0.0, 0.0,  
 0.0, 1.0, 0.0, -1.0 / yl,  
 0.0, 0.0, 1.0, 0.0,  
 0.0, 0.0, 0.0, 0.0};
```

- yl is light source height
- Assume drawPolygon(); draws object



# Saving the ModelView Matrix State

- Assume xl, yl, zl hold light coordinates
- Core OpenGL code (compatibility code is similar)

```
openGLMatrix.MatrixMode(OpenGLMatrix::ModelView);  
// here, set the model view matrix, in the usual way  
// ...
```

```
drawPolygon(); // draw normally  
openGLMatrix.PushMatrix(); // save current matrix  
openGLMatrix.Translate(xl, yl, zl); // translate back  
openGLMatrix.MultMatrix(m); // project  
openGLMatrix.Translate(-xl, -yl, -zl); // move light to origin
```

```
float ms[16];  
openGLMatrix.GetMatrix(ms); // read the shadow matrix
```

# Saving the ModelView Matrix State (cont.)

```
// upload the shadow matrix to the GPU
pipelineProgram->SetUniformVariableMatrix4fv(
    "modelViewMatrix", GL_FALSE, ms);

drawPolygon(); // draw polygon again for shadow

// restore original modelview matrix
openGLMatrix.PopMatrix();
openGLMatrix.GetMatrix(ms);
pipelineProgram->SetUniformVariableMatrix4fv(
    "modelViewMatrix", GL_FALSE, ms);

// continue rendering more objects, as usual ...
```

# The Matrix and Attribute Stacks

- Mechanism to save and restore state
  - `{OpenGLMatrix::, gl}PushMatrix();`
  - `{OpenGLMatrix::, gl}PopMatrix();`
- Apply to current matrix
- In compatibility profile, can also save current attribute values
  - Examples: color, lighting
  - `glPushAttrib(GLbitfield mask);`
  - `glPopAttrib();`
  - Mask determines which attributes are saved
  - This feature has been removed in the core profile

# Drawing on a Surface

- Shimmering (“z-buffer fighting”) when drawing shadow on surface
- Due to limited precision of depth buffer
- Solution: slightly displace either the surface or the shadow

(`glPolygonOffset`  
in OpenGL)



z-buffer  
fighting



no z-buffer  
fighting

# Drawing on a Surface

Or use general technique

1. Set depth buffer to read-only, draw surface
2. Set depth buffer to read-write, draw shadow
3. Set color buffer to read-only, draw surface again
4. Set color buffer to read-write

depth buffer



color buffer

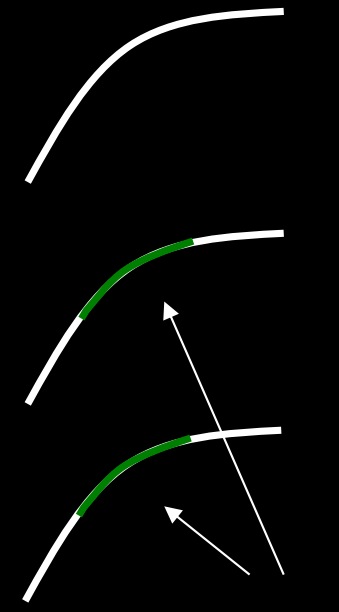

shadow  
on surface

# Outline

- Projections and Shadows
- Hierarchical Models

# Hierarchical Models

- Many graphical objects are structured
- Exploit structure for
  - Efficient rendering
  - Example: tree leaves
  - Concise specification of model parameters
  - Example: joint angles
  - Physical realism
- Structure often naturally hierarchical



# Instance Transformation

- Often we need several instances of an object
  - Wheels of a car
  - Arms or legs of a figure
  - Chess pieces





# Instance Transformation

- Instances can be shared across space or time
- Write a function that renders the object in “standard” configuration
- Apply transformations to different instances
- Typical order: scaling, rotation, translation

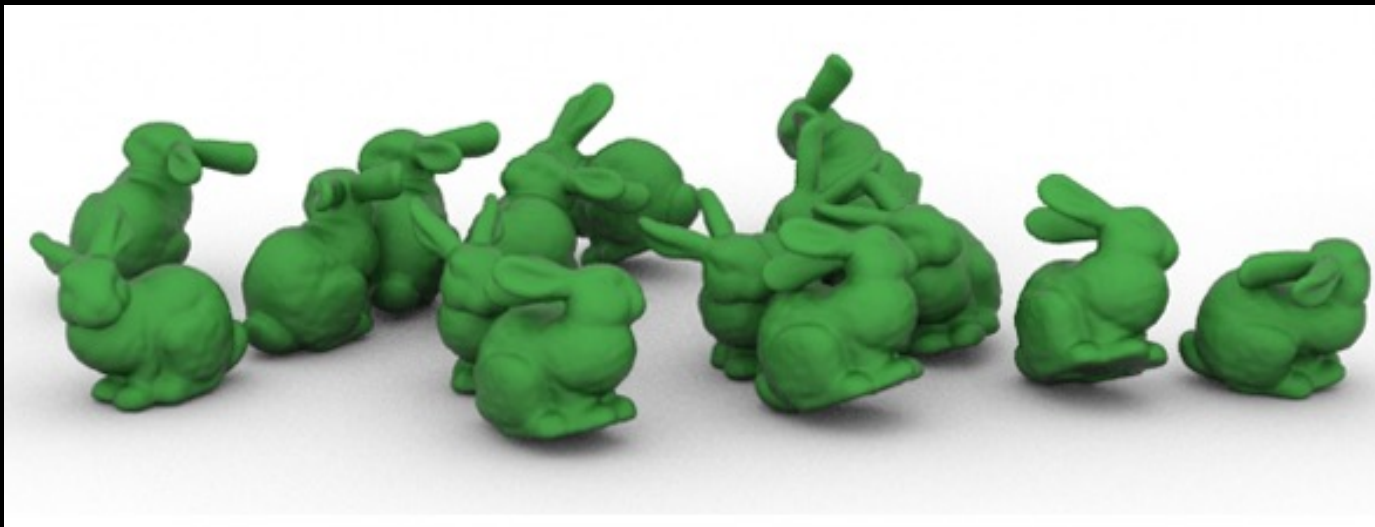

# Sample Instance Transformation

```
openGLMatrix.MatrixMode(OpenGLMatrix::ModelView);  
openGLMatrix.LoadIdentity();  
openGLMatrix.Translate(...);  
openGLMatrix.Rotate(...);  
openGLMatrix.Scale(...);  
// ... upload modelview matrix to GPU, as usual ...  
renderCylinder(...);
```

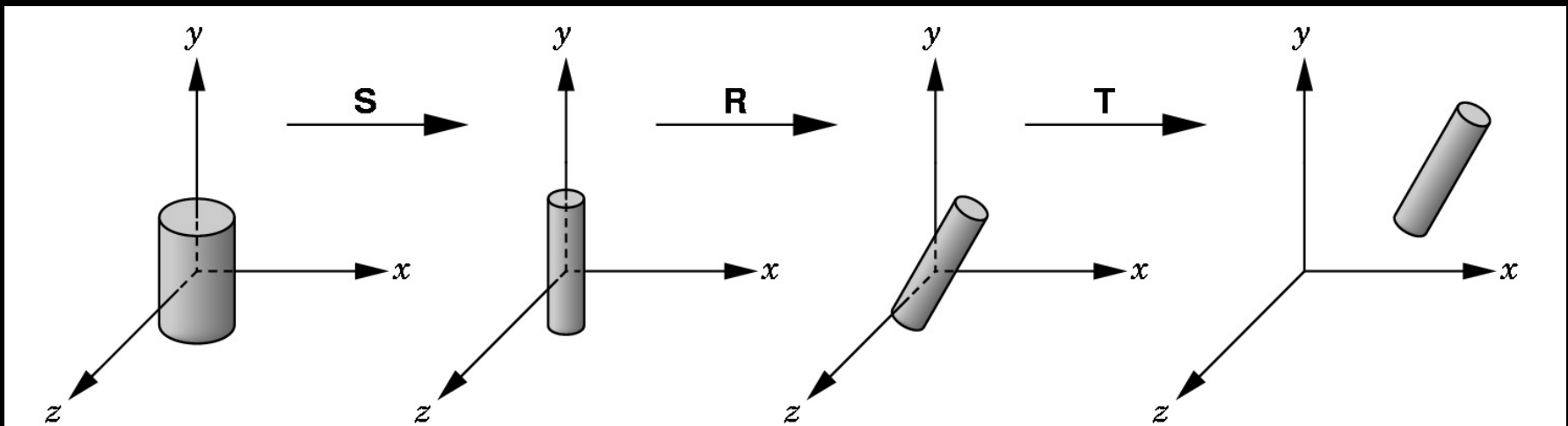

# Drawing a Compound Object

- Example: simple “robot arm”

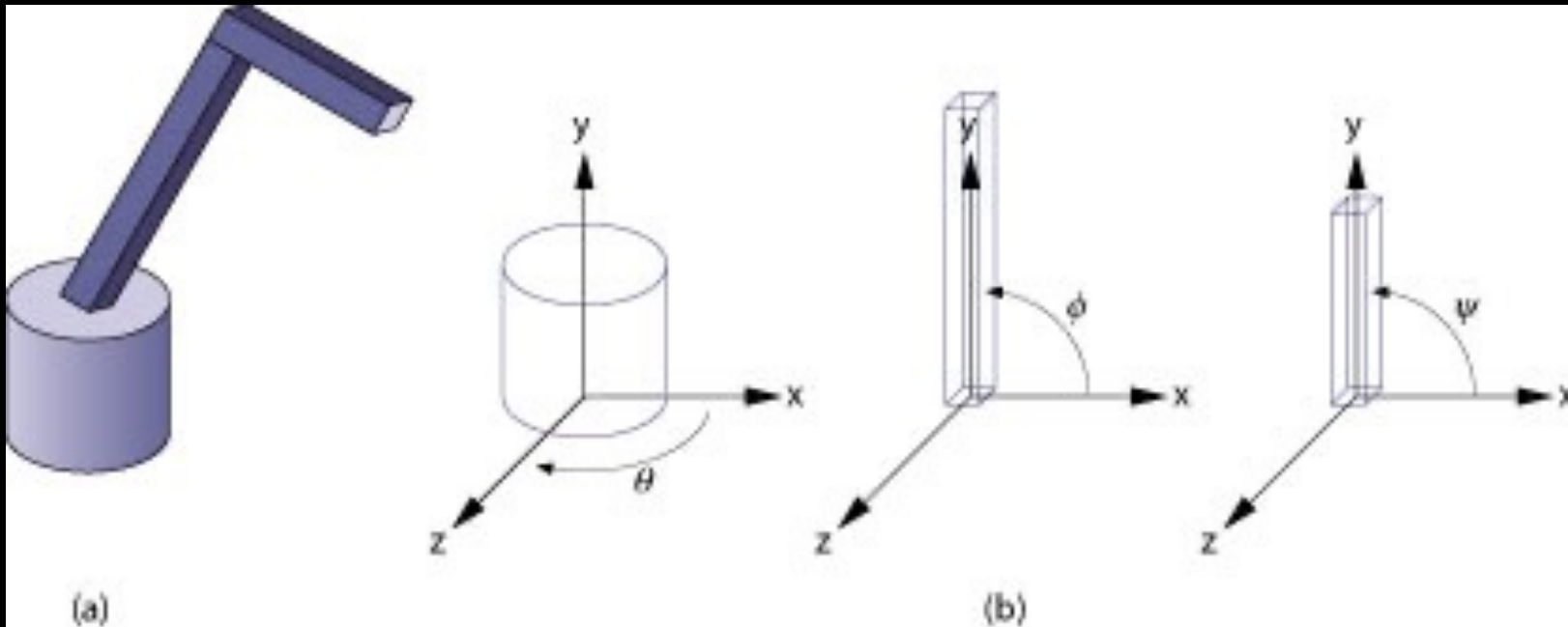

Base rotation  $\theta$ , arm angle  $\phi$ , joint angle  $\psi$

# Hierarchical Objects and Animation

- Drawing functions are time-invariant and draw the object in a canonical position:  
drawBase(); drawLowerArm(); drawUpperArm();
- Can be easily stored in a VBO
- Change parameters of model with time

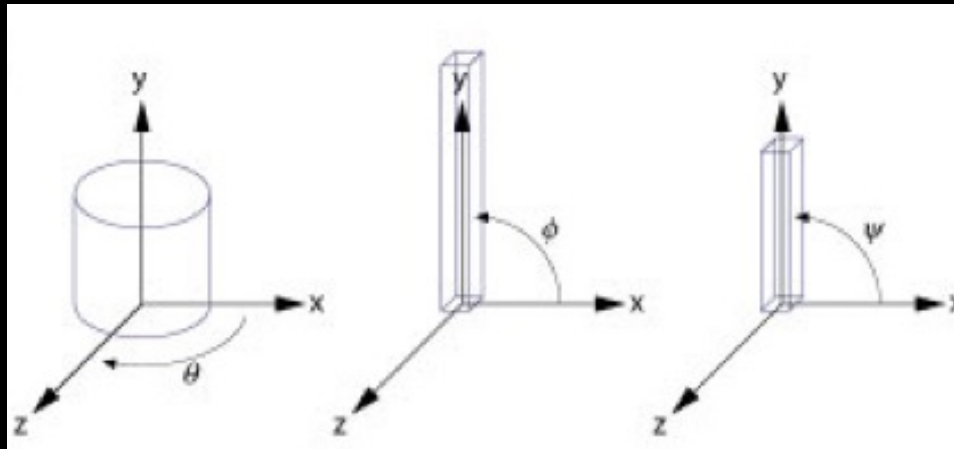

# Interleave Drawing & Transformation

- $h1$  = height of base,  $h2$  = length of lower arm
- This is pseudocode (must upload matrix to GPU)

```
void drawRobot(GLfloat theta,  
              GLfloat phi, GLfloat psi)  
{  
    Rotate(theta, 0.0, 1.0, 0.0);  
    drawBase();  
    Translate(0.0, h1, 0.0);  
    Rotate(phi, 0.0, 0.0, 1.0);  
    drawLowerArm();  
    Translate(0.0, h2, 0.0);  
    Rotate(psi, 0.0, 0.0, 1.0);  
    drawUpperArm();  
}
```

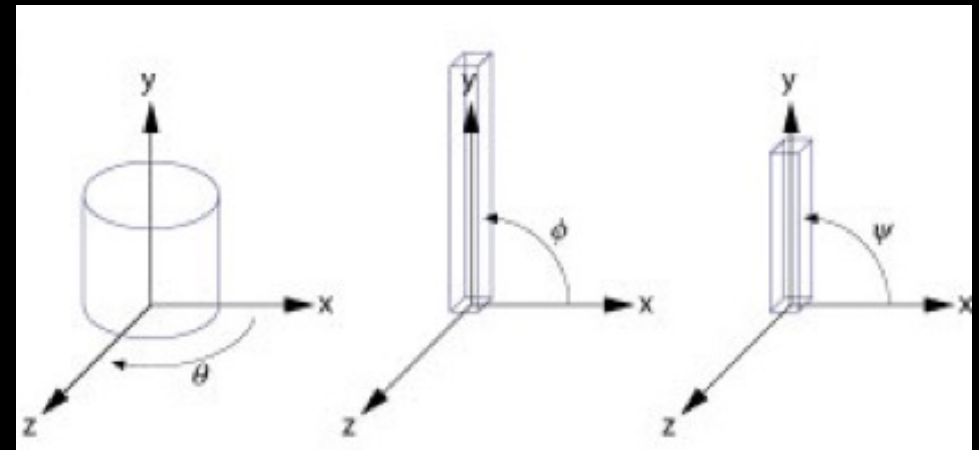

# More Complex Objects

- Tree rather than linear structure
- Interleave along each branch
- Use push and pop to save state

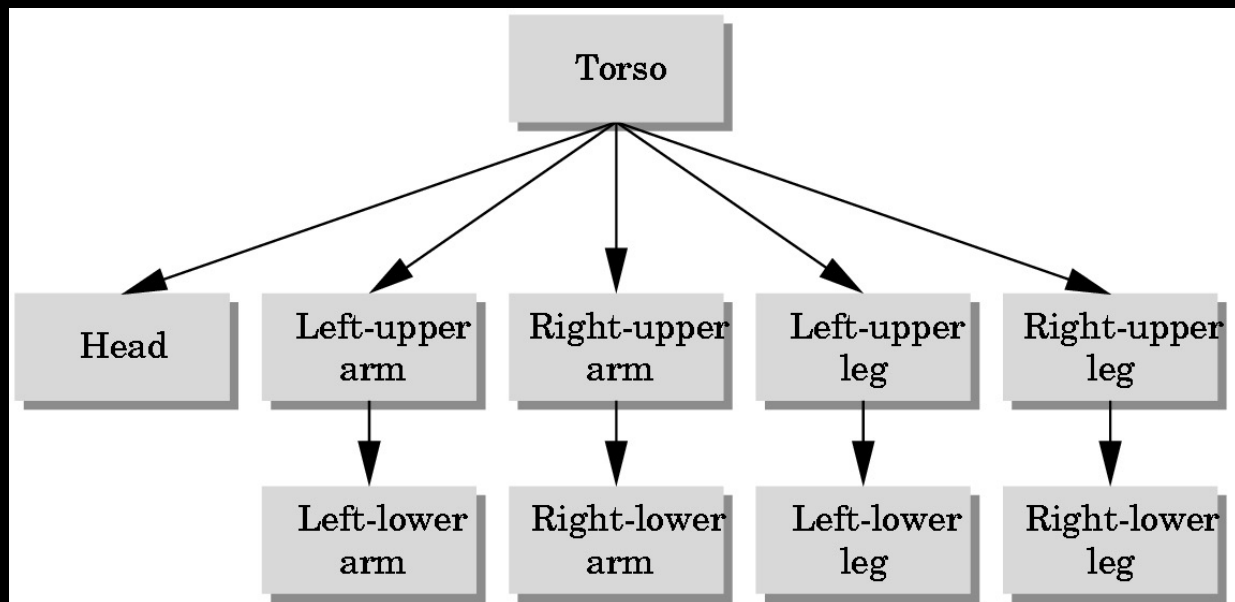
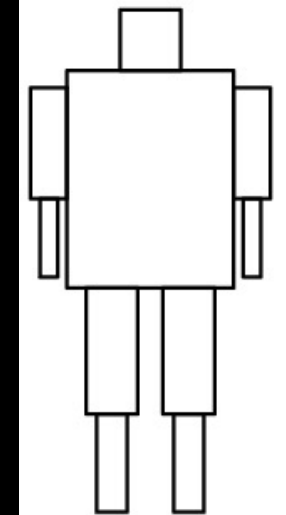

# Hierarchical Tree Traversal

- Order not necessarily fixed (breadth-first, depth-first, etc.)
- Example:

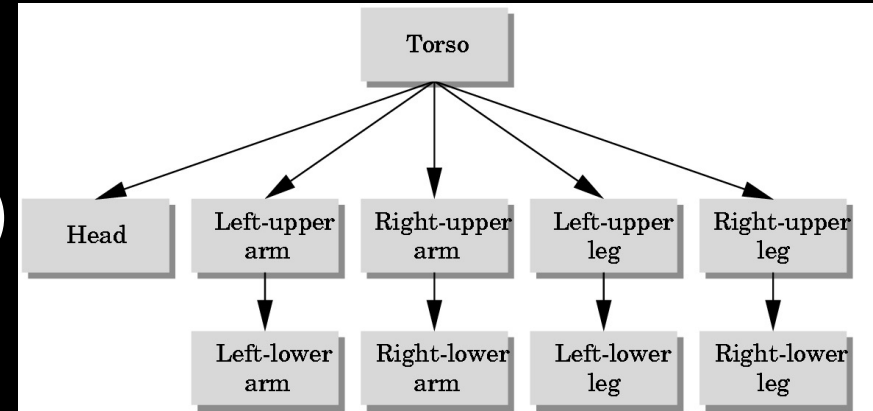

```
void drawFigure()  
{  
    PushMatrix(); // save  
    drawTorso();  
    Translate(...); // move head  
    Rotate(...); // rotate head  
    drawHead();  
    PopMatrix(); // restore  
    PushMatrix();
```

```
    Translate(...);  
    Rotate(...);  
    drawLeftUpperArm();  
    Translate(...)  
    Rotate(...)  
    drawLeftLowerArm();  
    PopMatrix();  
    ... }  
}
```

# Summary

- Projections and Shadows
- Hierarchical Models