

**CSCI 520**  
**Computer Animation**  
**and Simulation**

# Computer Animation and Simulation

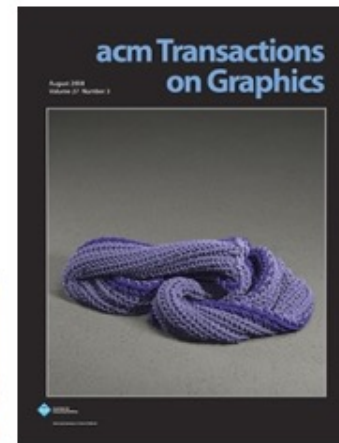
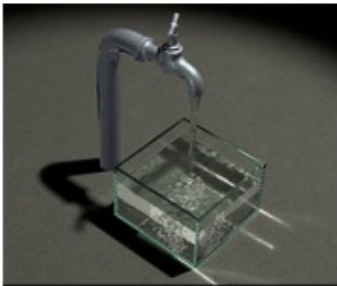
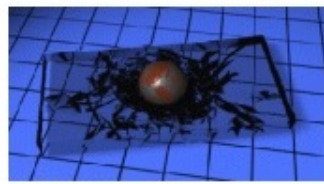

# About the teacher

- Full professor in CS
- Post-doc at MIT
- PhD, Carnegie Mellon University
- [jnb@usc.edu](mailto:jnb@usc.edu)



- **Background:**

BSc Mathematics

PhD Computer Science

- **Research interests:**

graphics, animation,

real-time physics, control, sound, haptics

- **Practice:**

- Tech transfer, startup companies  
(Ziva Dynamics)



# Teaching Assistant

- Huanyu Chen
- Tuesday, 3:00-5:00pm
- Location: TBA



# Who is the course for

- PhD students
- MSc students
- Advanced undergraduates
  
- CS 420 or 580 background will be very helpful !!

# Why take this course

- Opens the door to jobs in computer graphics
- Make better games
- Put math and physics to use in the real world
- Real-time graphics is cool
- Impress your friends with demos



# Course Information Online

<https://viterbi-web.usc.edu/~jbarbic/cs520-s23/>

- Schedule (slides, readings)
- Assignments (details, due dates)
- Software (libraries, hints)
- Resources (books, tutorials, links)

Submit assignments on Blackboard:

<https://blackboard.usc.edu>

Forum for questions is on Piazza:

<https://piazza.com/usc/spring2023/csci520/home>



# Prerequisites

- Grade of at least B in CS420 or CS580, or explicit permission of instructor
- Familiarity with calculus, linear algebra and numerical computation
- C/C++ programming skills
- See me if you are missing any and we haven't discussed it

# Recommended Textbooks

- **Rick Parent: Computer Animation, Second Edition: Algorithms and Techniques**
- **OpenGL Programming Guide (“Red Book”)**  
Basic version also available on-line (see [Resources](#))

# Evaluation

- Assignments: 3 x 21%
- Final Exam: 37%

# Academic integrity

- **No collaboration!**
- Do not copy any parts of any of the assignments from anyone
- Do not look at other students' code, papers, assignments or exams
- USC Office of Student Judicial Affairs and Community Standards will be notified

# Assignment Policies

- Programming assignments
  - Hand in via Blackboard by end of due date
  - Functionality and features
  - Style and documentation
  - Artistic impression
- 3 late days, usable any time during semester
- Academic integrity policy applied rigorously

# Class goals

- Gain ability to create animations and 3D simulations
- Learn a 3D graphics API (or improve skills)
- Improve code optimization skills

# Applications

- Virtual reality
- Interactive computer animation
- Surgical simulation; preoperative planning
- Computational robotics; manipulation
- Video games
- Assembly planning
- Scientific visualization
- Education
- E-commerce

# Keyframe Animation

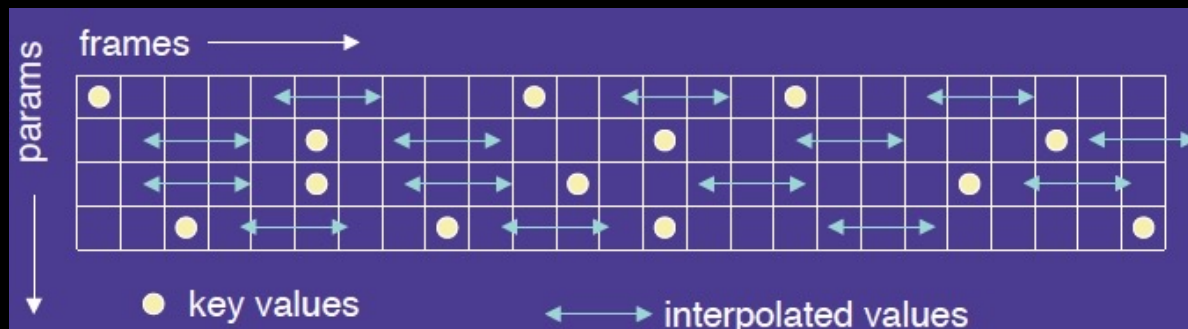



# Motion Capture



# Inverse Kinematics

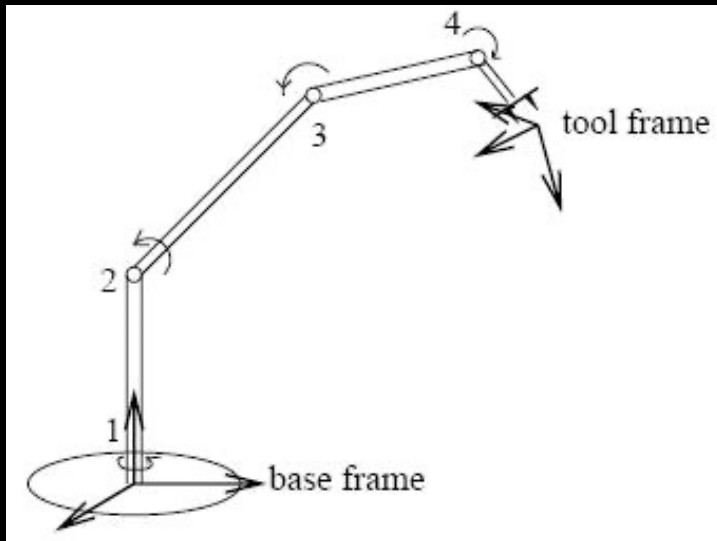

[www.learnartificialneuralnetworks.com](http://www.learnartificialneuralnetworks.com)

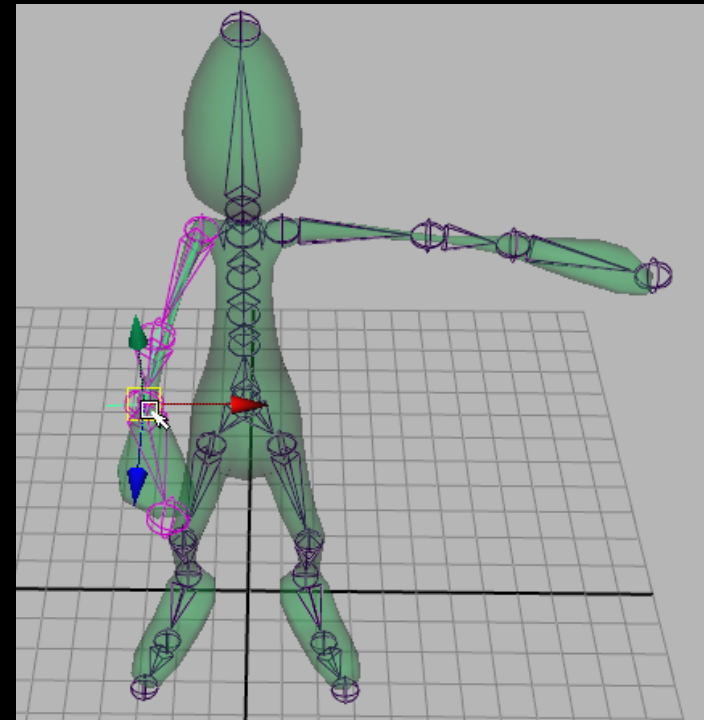

source: Autodesk

# Character Rigging

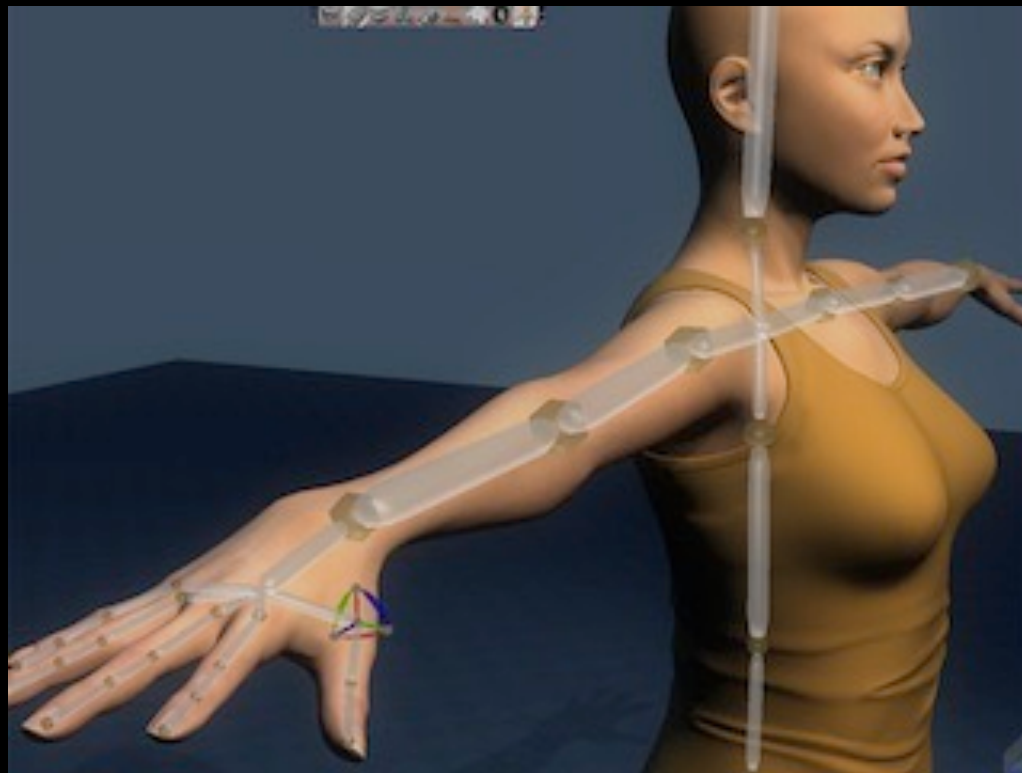

# Facial Animation





# Crowd Animation

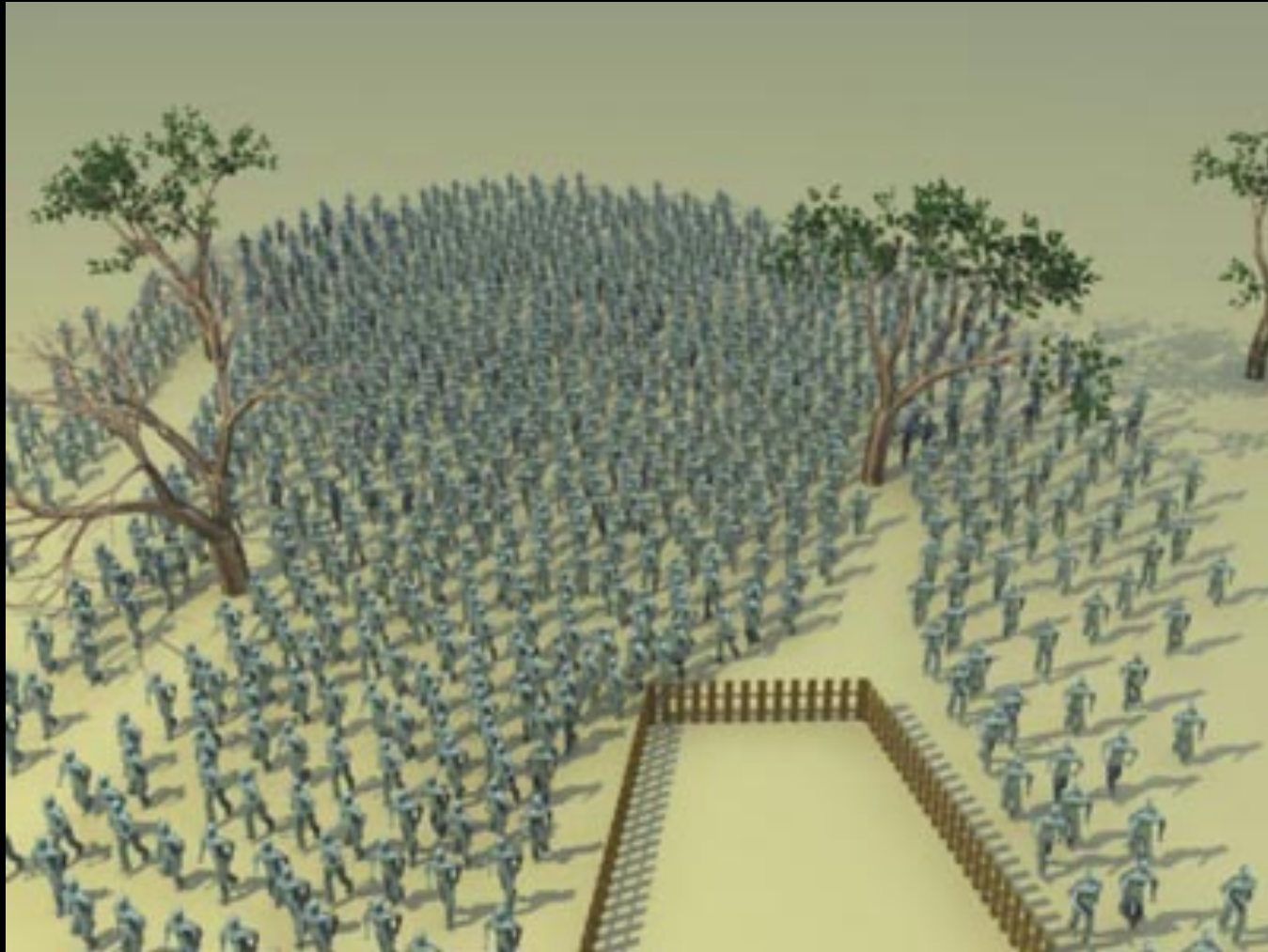

# Crowd Animation

## Continuum Crowds

Adrien Treuille  
Seth Cooper  
Zoran Popović

# Maya



# Fluids

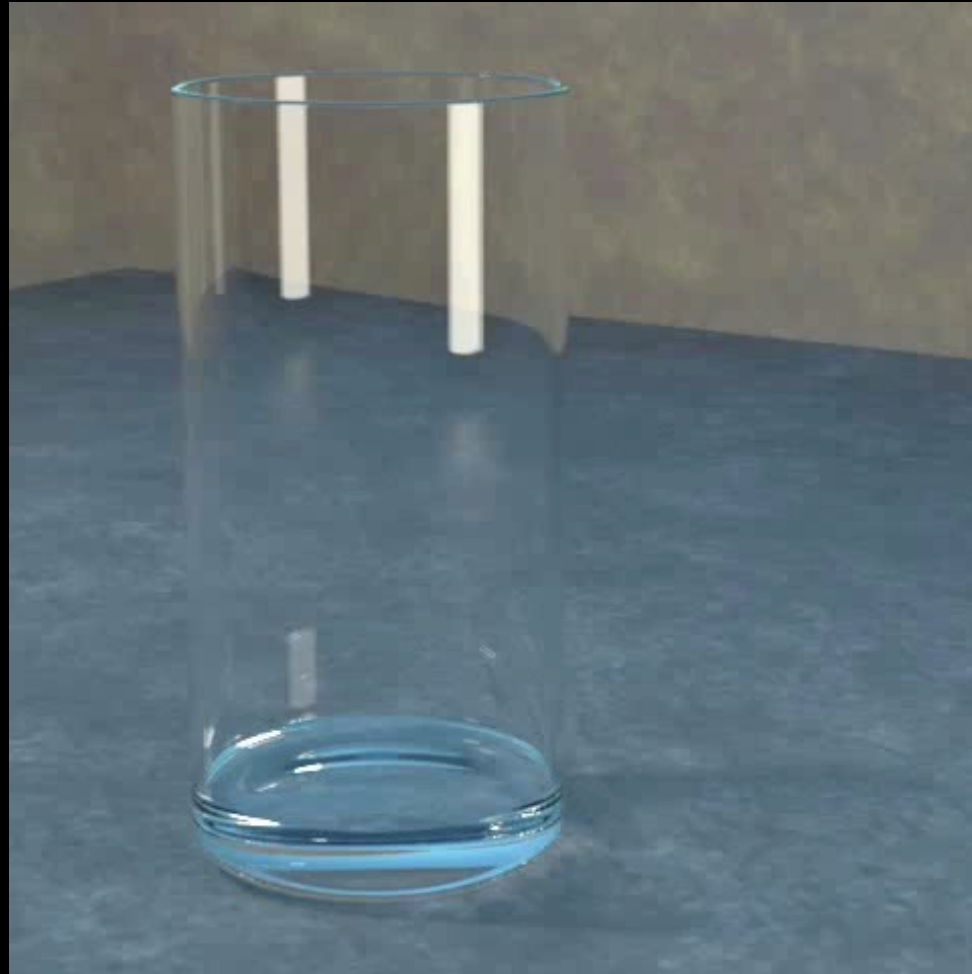



# Deformations

Vertices: 45882  
Triangles: 105788



# Cloth

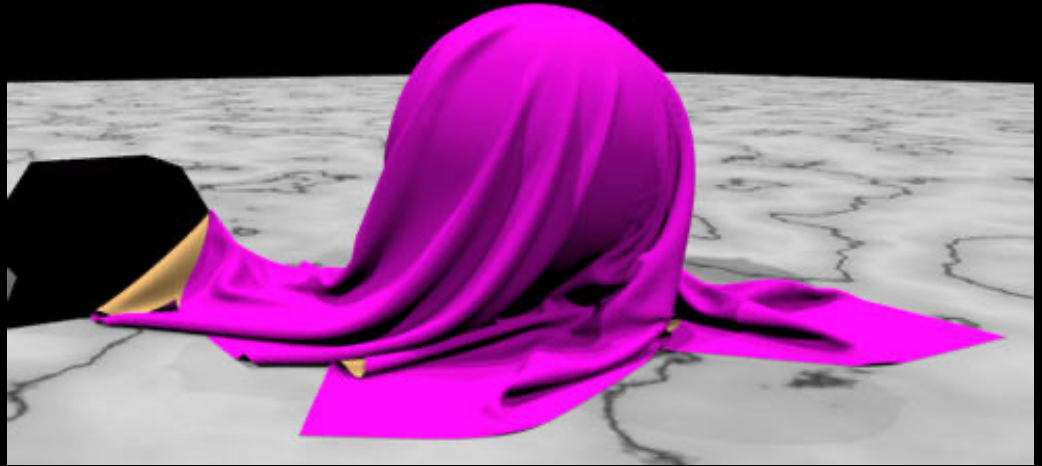

# Simulating Large Models

---



# Simulating Large Models

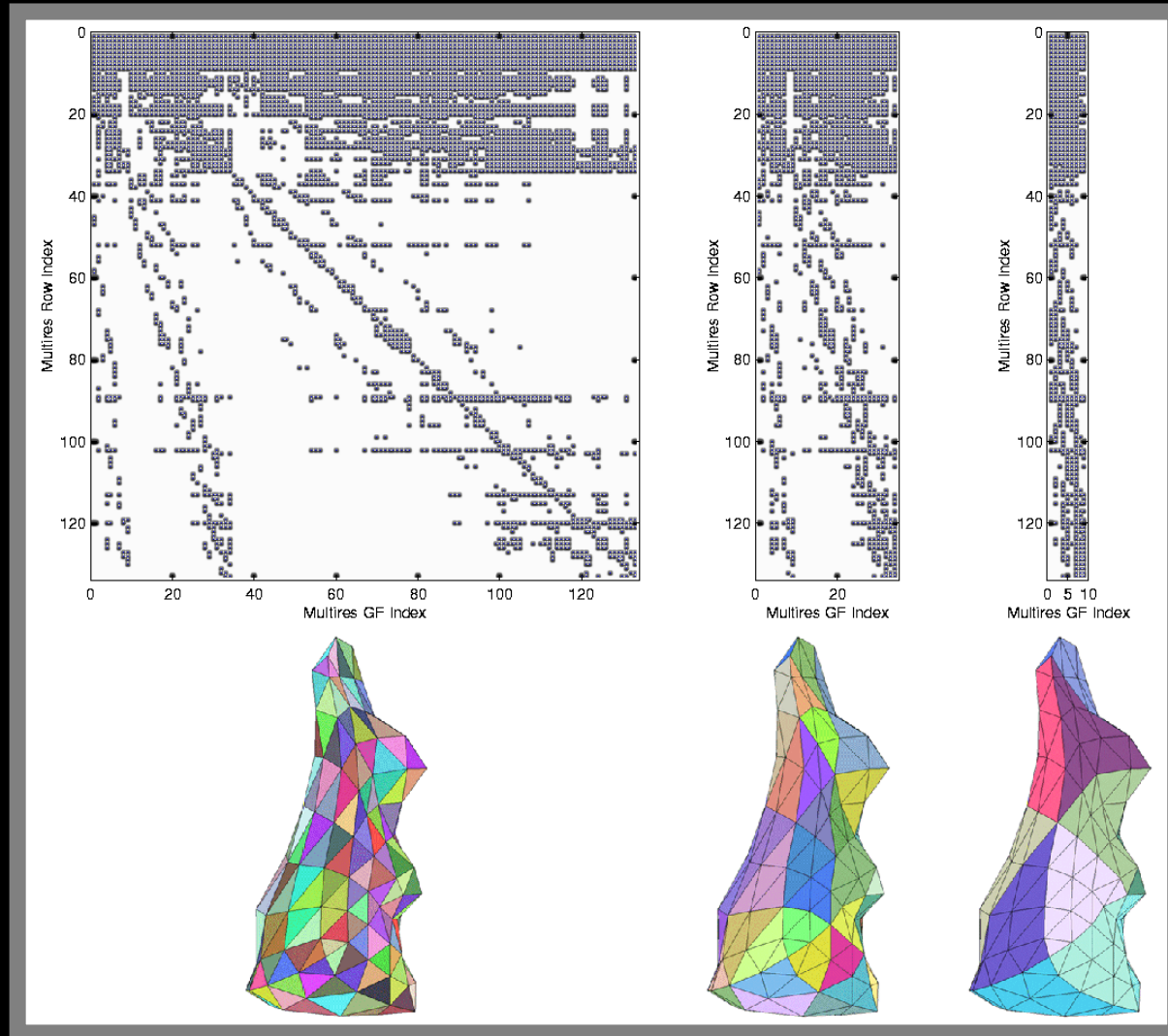

# Sound

Modal renderer



Source:  
CMU

# Self-collision detection

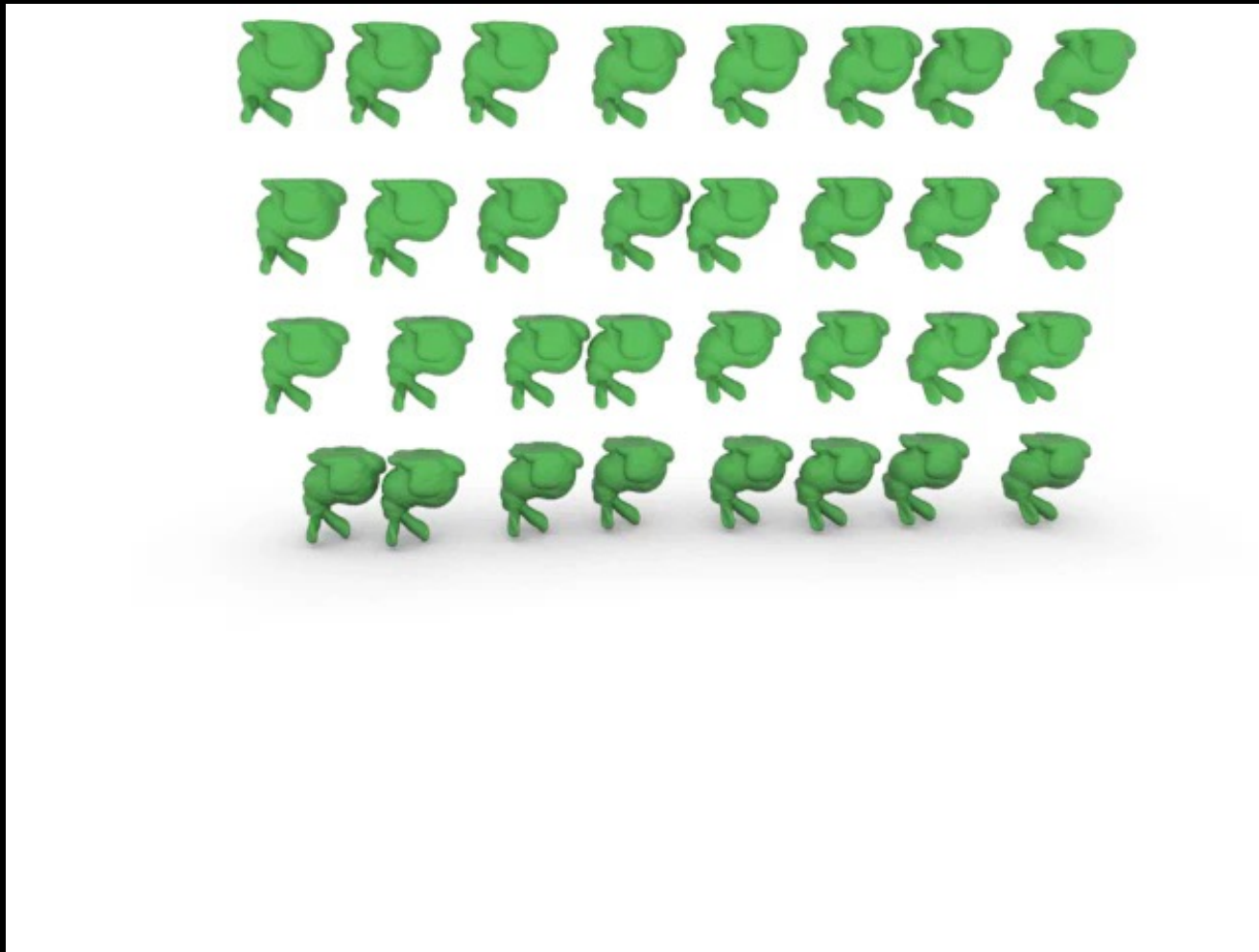



# GPU programming



- Vertex shader
- Fragment shader
- CUDA
- OpenCL

# Physics in games

Real-Time Deformation and Fracture  
in a Game Environment

Eric Parker  
Pixelux Entertainment

James O'Brien  
U.C. Berkeley

Video Edited by Sebastian Burke

From the proceedings of SCA 2009, New Orleans



# Force-feedback Rendering

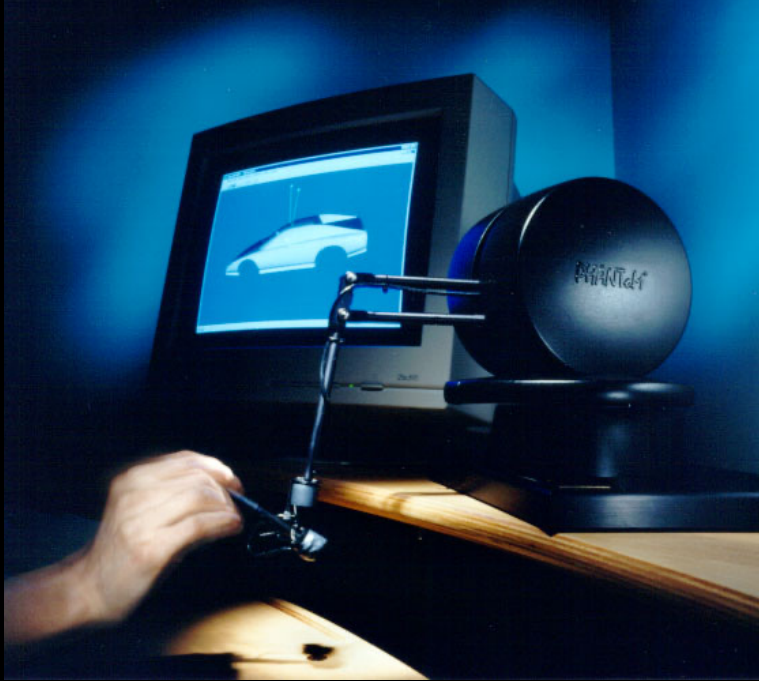

# Haptic Interfaces

- hap·tic ('hap-tik)  
*adj.*  
Of or relating to the sense  
of touch; tactile.

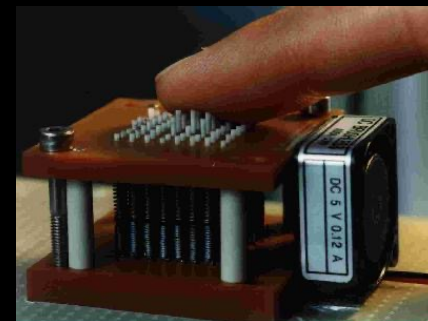

# Surgical Simulation



Source:  
Cornell University

# Multibody dynamics

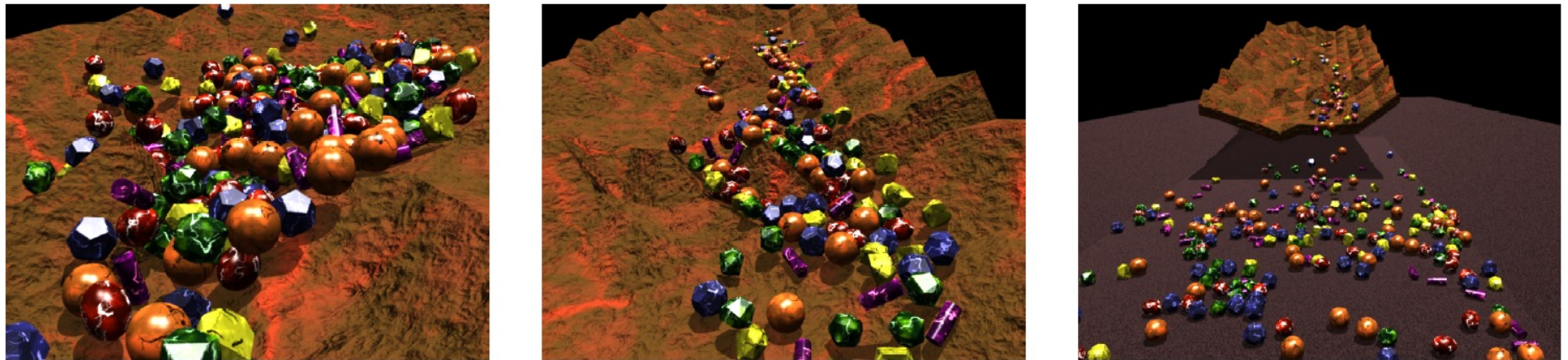

Figure 1: *Avalanche*: 300 rocks tumble down a mountainside.

## TOPICS TO BE COVERED:

- Overview of computer animation
- Primer on numerical linear algebra
- Dynamical systems, numerical integration of ODEs
- Constraints and contact
- Character Rigging
- Inverse Kinematics
- Maya
- Crowds
- Rigid body dynamics
- Collision detection
- Structured deformable objects (solids, cloth, hair)
- Fracture and cutting
- Fluids (Navier-Stokes)
- Haptics
- Sound simulation (acoustics)
- Programmable graphics hardware (GPUs)
- Case study: Havok engine for physics in games
- Motion capture

**CSCI 520**  
**Computer Animation**  
**and Simulation**

<http://www.jernejbarbic.com>